



Cross Racer

framehoogte	XS (44)	S (48)	M (54)	L (58)	XL (61)
zitbuislengte	A 440 mm	490 mm	540 mm	590 mm	610 mm
bovenbuislengte	B 565 mm	580 mm	590 mm	600 mm	610 mm
achterbruglengte	C 440 mm	440 mm	440 mm	440 mm	440 mm
trapasoffset	D 60 mm	55 mm	55 mm	55 mm	55 mm
balhoofd lengte	E 130 mm	130 mm	135 mm	160 mm	180 mm
balhoofdhoek	α 71°	71°	71°	71°	71°
zitbuishoek	β 74,5°	73,5°	73,5°	73,5°	73,5°

Cross RS

♂	XS (44)	S (48)	M (54)	L (58)	XL (61)	♀	S (44)	M (48)	L (54)
A	440 mm	460 mm	540 mm	590 mm	610 mm	A	440 mm	480 mm	540 mm
B	575 mm	590 mm	600 mm	610 mm	630 mm	B	565 mm	580 mm	590 mm
C	440 mm	440 mm	440 mm	440 mm	440 mm	C	440 mm	440 mm	440 mm
D	55 mm	45 mm	45 mm	45 mm	45 mm	D	55 mm	45 mm	45 mm
E	130 mm	130 mm	135 mm	150 mm	160 mm	E	130 mm	130 mm	135 mm
α	71°	71°	71°	71°	71°	α	71°	71°	71°
β	74,5°	73,5°	73,5°	73°	72,5°	β	74,5°	73,5°	73,5°

Cross Mover

framehoogte	♂ XS (44)	S (48)	M (54)	L (58)	XL (61)	♀ S (44)	M (48)	L (54)
zitbuislengte	A 440 mm	480 mm	540 mm	580 mm	610 mm	A 440 mm	480 mm	540 mm
bovenbuislengte	B 575 mm	590 mm	600 mm	610 mm	630 mm	B 565 mm	580 mm	590 mm
achterbruglengte	C 440 mm	440 mm	440 mm	440 mm	440 mm	C 440 mm	440 mm	440 mm
trapasoffset	D 60 mm	55 mm	55 mm	55 mm	55 mm	D 60 mm	55 mm	55 mm
balhoofd lengte	E 130 mm	130 mm	135 mm	150 mm	160 mm	E 130 mm	130 mm	135 mm
balhoofdhoek	α 71°	71°	71°	71°	71°	α 71°	71°	71°
zitbuishoek	β 74,5°	73,5°	73,5°	73,5°	73,5°	β 74,5°	73,5°	73,5°

Cross Mover 11

♂	XS (44)	S (48)	M (54)	L (58)	XL (61)	♀	S (44)	M (48)	L (54)
A	440 mm	480 mm	540 mm	580 mm	610 mm	A	440 mm	480 mm	540 mm
B	575 mm	590 mm	600 mm	610 mm	630 mm	B	565 mm	580 mm	590 mm
C	440 mm	440 mm	440 mm	440 mm	440 mm	C	440 mm	440 mm	440 mm
D	60 mm	55 mm	55 mm	55 mm	55 mm	D	60 mm	55 mm	55 mm
E	130 mm	130 mm	135 mm	150 mm	160 mm	E	130 mm	130 mm	135 mm
α	71°	71°	71°	71°	71°	α	71°	71°	71°
β	74,5°	73,5°	73,5°	73,5°	73,5°	β	74,5°	73,5°	73,5°

Cross Flyer

framehoogte	♂ XS (44)	S (48)	M (54)	L (58)	XL (61)	♀ S (44)	M (48)	L (54)
zitbuislengte	A 440 mm	480 mm	540 mm	580 mm	610 mm	A 440 mm	480 mm	540 mm
bovenbuislengte	B 565 mm	580 mm	590 mm	600 mm	610 mm	B 555 mm	570 mm	580 mm
achterbruglengte	C 440 mm	440 mm	440 mm	440 mm	440 mm	C 440 mm	440 mm	440 mm
trapasoffset	D 60 mm	55 mm	55 mm	55 mm	55 mm	D 60 mm	55 mm	55 mm
balhoofd lengte	E 130 mm	130 mm	135 mm	150 mm	160 mm	E 130 mm	130 mm	135 mm
balhoofdhoek	α 71°	71°	71°	71°	71°	α 71°	71°	71°
zitbuishoek	β 74,5°	73,5°	73,5°	73°	72,5°	β 74,5°	73,5°	73,5°

Cross Swing

♂	XS (44)	S (48)	M (54)	L (58)	XL (61)	♀	S (44)	M (48)	L (54)
A	440 mm	480 mm	540 mm	580 mm	610 mm	A	440 mm	480 mm	540 mm
B	565 mm	580 mm	590 mm	600 mm	610 mm	B	555 mm	570 mm	580 mm
C	440 mm	440 mm	440 mm	440 mm	440 mm	C	440 mm	440 mm	440 mm
D	60 mm	55 mm	55 mm	55 mm	55 mm	D	60 mm	55 mm	55 mm
E	130 mm	130 mm	135 mm	150 mm	160 mm	E	130 mm	130 mm	135 mm
α	71°	71°	71°	71°	71°	α	71°	71°	71°
β	74,5°	73,5°	73,5°	73°	72,5°	β	74,5°	73,5°	73,5°

Cross Tail

framehoogte	♂ XS (44)	S (48)	M (54)	L (58)	XL (61)	♀ S (44)	M (48)	L (54)
zitbuislengte	A 440 mm	480 mm	540 mm	580 mm	610 mm	A 440 mm	480 mm	540 mm
bovenbuislengte	B 565 mm	580 mm	590 mm	600 mm	610 mm	B 555 mm	570 mm	580 mm
achterbruglengte	C 440 mm	440 mm	440 mm	440 mm	440 mm	C 440 mm	440 mm	440 mm
trapasoffset	D 60 mm	55 mm	55 mm	55 mm	55 mm	D 60 mm	55 mm	55 mm
balhoofd lengte	E 130 mm	130 mm	135 mm	150 mm	160 mm	E 130 mm	130 mm	135 mm
balhoofdhoek	α 71°	71°	71°	71°	71°	α 71°	71°	71°
zitbuishoek	β 74,5°	73,5°	73,5°	73°	72,5°	β 74,5°	73,5°	73,5°

Cross Mad

	S (46)	M (52)	L (56)	XL (59)
A	460 mm	520 mm	590 mm	590 mm
B	580 mm	590 mm	600 mm	610 mm
C	440 mm	440 mm	440 mm	440 mm
D	55 mm	55 mm	55 mm	55 mm
E	130 mm	135 mm	160 mm	180 mm
α	71°	71°	71°	71°
β	73,5°	73,5°	73,5°	73,5°

Sturmvogel

	S (42)	M (47)	L (52)
A	420 mm	470 mm	520 mm
B	570 mm	585 mm	600 mm
C	430 mm	430 mm	430 mm
D	43 mm	43 mm	43 mm
E	130 mm	140 mm	160 mm
α	70,5°	71°	71°
β	74°	73°	73°

Nova

	M (32)
framehoogte	M (32)
zitbuislengte	A 320 mm
bovenbuislengte	B 507 mm
achterbruglengte	C 410 mm
trapasoffset	D 25 mm
balhoofd lengte	E 120 mm
balhoofdhoek	α 70°
zitbuishoek	β 71,5°

Nos

	M (32)
framehoogte	M (32)
zitbuislengte	A 320 mm
bovenbuislengte	B 507 mm
achterbruglengte	C 410 mm
trapasoffset	D 25 mm
balhoofd lengte	E 120 mm
balhoofdhoek	α 70°
zitbuishoek	β 71,5°

Tokee 24

	M (32)
framehoogte	M (32)
zitbuislengte	A 320 mm
bovenbuislengte	B 507 mm
achterbruglengte	C 410 mm
trapasoffset	D 25 mm
balhoofd lengte	E 120 mm
balhoofdhoek	α 70°
zitbuishoek	β 71,5°

Devilzone / Stonecold

	S (38)	M (42)	L (47)	XL (52)
framehoogte	S (38)	M (42)	L (47)	XL (52)
zitbuislengte	A 380 mm	420 mm	470 mm	520 mm
bovenbuislengte	B 545 mm	560 mm	575 mm	590 mm
achterbruglengte	C 420 mm	420 mm	420 mm	420 mm
trapasoffset	D 20 mm	15 mm	15 mm	15 mm
balhoofd lengte	E 130 mm	130 mm	140 mm	155 mm
balhoofdhoek	α 69°	69°	69°	69°
zitbuishoek	β 73°	73°	73°	73°

Aquarius

	M (24,5)
framehoogte	M (24,5)
zitbuislengte	A 245 mm
bovenbuislengte	B 520 mm
achterbruglengte	C 349 mm
trapasoffset	D -35 mm
balhoofd lengte	E 100 mm
balhoofdhoek	α 74°
zitbuishoek	β 70,5°

Pow

	M (24)
framehoogte	M (24)
zitbuislengte	A 242 mm
bovenbuislengte	B 508 mm
achterbruglengte	C 352 mm
trapasoffset	D -38 mm
balhoofd lengte	E 100 mm
balhoofdhoek	α 74,5°
zitbuishoek	β 71°

Novice Race

	M (24)
framehoogte	M (24)
zitbuislengte	A 242 mm
bovenbuislengte	B 566 mm
achterbruglengte	C 377 mm
trapasoffset	D -52 mm
balhoofd lengte	E 114 mm
balhoofdhoek	α 74°
zitbuishoek	β 70,5°



FRAMEGEOMETRIE

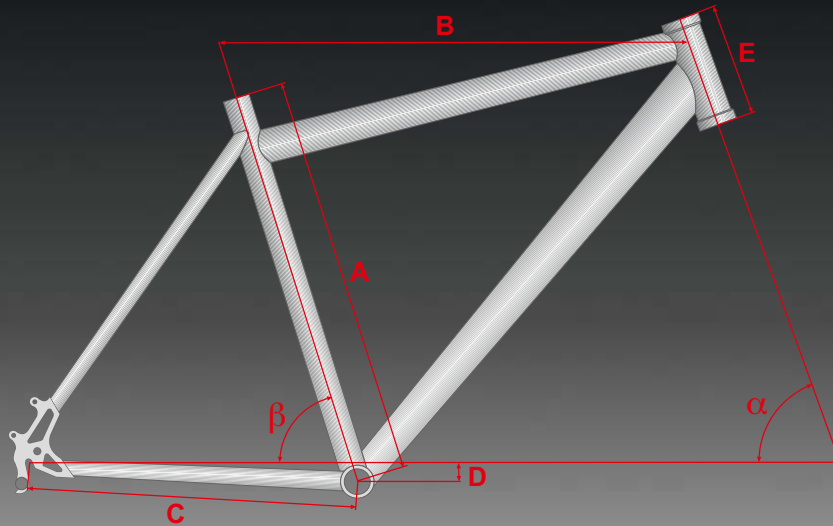

Black Adder 29/Tirone 29				
framehoogte	M (47)	L (52)	XL (57)	
zitbuislengte	A 470 mm	520 mm	570 mm	
bovenbuislengte	B 595 mm	615 mm	635 mm	
achterbruglengte	C 455 mm	460 mm	460 mm	
trapasoffset	D 60 mm	60 mm	55 mm	
talhoofdengte	E 115 mm	115 mm	140 mm	
balhoofdhoek	α 71°	71,5°	71,5°	
zitbuishoek	β 73°	72,5°	72°	

Copperhead 29/29 Plus				
framehoogte	M (47)	L (52)	XL (57)	
zitbuislengte	A 470 mm	520 mm	570 mm	
bovenbuislengte	B 595 mm	615 mm	635 mm	
achterbruglengte	C 455 mm	460 mm	460 mm	
trapasoffset	D 60 mm	60 mm	55 mm	
talhoofdengte	E 115 mm	115 mm	140 mm	
balhoofdhoek	α 71°	71,5°	71,5°	
zitbuishoek	β 73°	72,5°	72°	

King Cobra Supreme 29				
framehoogte	M (47)	L (52)	XL (57)	
zitbuislengte	A 470 mm	520 mm	570 mm	
bovenbuislengte	B 595 mm	615 mm	635 mm	
achterbruglengte	C 455 mm	460 mm	460 mm	
trapasoffset	D 60 mm	60 mm	55 mm	
talhoofdengte	E 115 mm	115 mm	140 mm	
balhoofdhoek	α 71°	71,5°	71,5°	
zitbuishoek	β 73°	72,5°	72°	

Black Adder				
framehoogte	S (42)	M (47)	L (52)	XL (57)
zitbuislengte	A 420 mm	470 mm	520 mm	570 mm
bovenbuislengte	B 585 mm	600 mm	615 mm	630 mm
achterbruglengte	C 428 mm	428 mm	433 mm	438 mm
trapasoffset	D 25 mm	20 mm	20 mm	15 mm
talhoofdengte	E 110 mm	120 mm	135 mm	165 mm
balhoofdhoek	α 70°	70°	70°	70°
zitbuishoek	β 73°	73°	73°	73°

Bushmaster/Copperhead				
framehoogte	S (42)	M (47)	L (52)	XL (57)
zitbuislengte	A 420 mm	470 mm	520 mm	570 mm
bovenbuislengte	B 575 mm	590 mm	605 mm	620 mm
achterbruglengte	C 425 mm	425 mm	430 mm	435 mm
trapasoffset	D 30 mm	25 mm	25 mm	25 mm
talhoofdengte	E 120 mm	130 mm	145 mm	175 mm
balhoofdhoek	α 70°	70°	70°	70°
zitbuishoek	β 73°	73°	73°	73°

Copperhead Carbon			
framehoogte	S (43)	M (48)	L (53)
zitbuislengte	A 430 mm	480 mm	530 mm
bovenbuislengte	B 575 mm	600 mm	615 mm
achterbruglengte	C 425 mm	425 mm	425 mm
trapasoffset	D 28 mm	28 mm	28 mm
talhoofdengte	E 120 mm	130 mm	145 mm
balhoofdhoek	α 69,5°	69,5°	69,5°
zitbuishoek	β 72,5°	72,5°	72,5°

Mover 11					
framehoogte	XS (38)	S (42)	M (47)	L (52)	XL (57)
zitbuislengte	A 380 mm	420 mm	470 mm	520 mm	570 mm
bovenbuislengte	B 550 mm	565 mm	580 mm	595 mm	610 mm
achterbruglengte	C 438 mm	438 mm	438 mm	438 mm	438 mm
trapasoffset	D 35 mm	35 mm	30 mm	30 mm	30 mm
talhoofdengte	E 130 mm	130 mm	140 mm	155 mm	185 mm
balhoofdhoek	α 70°	70°	70°	70°	70°
zitbuishoek	β 73°	73°	73°	73°	73°

King Boa Disc					
framehoogte	XS (38)	S (42)	M (47)	L (52)	XL (57)
zitbuislengte	A 380 mm	420 mm	470 mm	520 mm	570 mm
bovenbuislengte	B 550 mm	565 mm	580 mm	595 mm	610 mm
achterbruglengte	C 425 mm	425 mm	425 mm	425 mm	425 mm
trapasoffset	D 35 mm	35 mm	30 mm	30 mm	30 mm
talhoofdengte	E 130 mm	130 mm	140 mm	155 mm	185 mm
balhoofdhoek	α 70°	70°	70°	70°	70°
zitbuishoek	β 73°	73°	73°	73°	73°

Aminga/Jinga				
framehoogte	XS (38)	S (42)	M (47)	L (52)
zitbuislengte	A 380 mm	420 mm	470 mm	520 mm
bovenbuislengte	B 540 mm	550 mm	565 mm	580 mm
achterbruglengte	C 425 mm	425 mm	425 mm	425 mm
trapasoffset	D 35 mm	35 mm	30 mm	30 mm
talhoofdengte	E 130 mm	130 mm	140 mm	155 mm
balhoofdhoek	α 70°	70°	70°	70°
zitbuishoek	β 73°	73°	73°	73°

Vanida/Zarena/Nandi				
framehoogte	XS (38)	S (42)	M (47)	L (52)
zitbuislengte	A 380 mm	420 mm	470 mm	520 mm
bovenbuislengte	B 535 mm	545 mm	560 mm	575 mm
achterbruglengte	C 425 mm	425 mm	425 mm	425 mm
trapasoffset	D 35 mm	35 mm	30 mm	30 mm
talhoofdengte	E 130 mm	130 mm	140 mm	155 mm
balhoofdhoek	α 70°	70°	70°	70°
zitbuishoek	β 73°	73°	73°	73°

Wild Rush			
framehoogte	S (43)	M (48)	L (53)
zitbuislengte	A 430 mm	480 mm	530 mm
bovenbuislengte	B 575 mm	590 mm	605 mm
achterbruglengte	C 435 mm	435 mm	435 mm
trapasoffset	D 0 mm	0 mm	0 mm
talhoofdengte	E 120 mm	130 mm	140 mm
balhoofdhoek	α 69°	69°	69°
zitbuishoek	β 72,5°	73°	73,5°

Copperhead FS			
framehoogte	S (43)	M (48)	L (53)
zitbuislengte	A 430 mm	480 mm	530 mm
bovenbuislengte	B 575 mm	590 mm	605 mm
achterbruglengte	C 430 mm	430 mm	430 mm
trapasoffset	D 10 mm	10 mm	10 mm
talhoofdengte	E 120 mm	130 mm	140 mm
balhoofdhoek	α 70°	70°	70°
zitbuishoek	β 72,5°	72,5°	72,5°

Wild Mojo			
framehoogte	S (43)	M (48)	L (53)
zitbuislengte	A 430 mm	480 mm	530 mm
bovenbuislengte	B 575 mm	590 mm	605 mm
achterbruglengte	C 435 mm	435 mm	435 mm
trapasoffset	D -15 mm	-15 mm	-15 mm
talhoofdengte	E 120 mm	130 mm	140 mm
balhoofdhoek	α 69°	69°	69°
zitbuishoek	β 72,5°	73°	73,5°

Wild Cup			
framehoogte	S (43)	M (48)	L (53)
zitbuislengte	A 430 mm	480 mm	530 mm
bovenbuislengte	B 575 mm	590 mm	605 mm
achterbruglengte	C 440 mm	440 mm	440 mm
trapasoffset	D 0 mm	0 mm	0 mm
talhoofdengte	E 120 mm	130 mm	140 mm
balhoofdhoek	α 69°	69°	69°
zitbuishoek	β 72,5°	72,5°	72,5°

Night Hawk				
framehoogte	S (50)	M (53)	L (56)	XL (59)
zitbuislengte	A 500 mm	530 mm	560 mm	590 mm
bovenbuislengte	B 538 mm	555 mm	575 mm	595 mm
achterbruglengte	C 410 mm	410 mm	415 mm	420 mm
trapasoffset	D 70 mm	70 mm	65 mm	65 mm
talhoofdengte	E 150 mm	170 mm	190 mm	210 mm
balhoofdhoek	α 72,5°	73°	73°	73,5°
zitbuishoek	β 73,5°	73°	73°	72,5°

Desert Falcon/Harrier									
framehoogte	XS (48)	S (50)	S (52)	M (54)	M (56)	L (58)	L (60)	XL (62)	XL (64)
zitbuislengte	A 480 mm	500 mm	520 mm	540 mm	560 mm	580 mm	600 mm	620 mm	640 mm
bovenbuislengte	B 525 mm	525 mm	530 mm	540 mm	550 mm	565 mm	575 mm	585 mm	595 mm
achterbruglengte	C 410 mm	410 mm	410 mm	410 mm	415 mm	415 mm	420 mm	420 mm	420 mm
trapasoffset	D 70 mm	70 mm	70 mm	70 mm	65 mm	65 mm	65 mm	65 mm	65 mm
talhoofdengte	E 130 mm	140 mm	150 mm	160 mm	170 mm	190 mm	210 mm	230 mm	250 mm
balhoofdhoek	α 72°	72°	72,5°	72,5°	72,5°	72,5°	73°	73°	73°
zitbuishoek	β 74,5°	74,5°	74,5°	74°	73,5°	73,5°	73°	72,5°	72°

Vulture					
framehoogte	XS (47)	S (50)	M (53)	L (56)	XL (59)
zitbuislengte	A 470 mm	500 mm	530 mm	560 mm	590 mm
bovenbuislengte	B 525 mm	535 mm	550 mm	570 mm	590 mm
achterbruglengte	C 410 mm	410 mm	410 mm	410 mm	410 mm
trapasoffset	D 70 mm	70 mm	65 mm	65 mm	65 mm
talhoofdengte	E 120 mm	130 mm	150 mm	180 mm	215 mm
balhoofdhoek	α 72°	72°	72,5°	72,5°	73°
zitbuishoek	β 74,5°	74,5°	74°	73,5°	73°

Ancura				
framehoogte	XS (48)	S (50)	M (52)	L (54)
zitbuislengte	A 480 mm	500 mm	520 mm	540 mm
bovenbuislengte	B 505 mm	515 mm	525 mm	535 mm
achterbruglengte	C 410 mm	410 mm	410 mm	410 mm
trapasoffset	D 70 mm	70 mm	65 mm	65 mm
talhoofdengte	E 110 mm	120 mm	140 mm	160 mm
balhoofdhoek	α 71°	72°	72,5°	72,5°
zitbuishoek	β 74,5°	74,5°	74,5°	74°

Cross RS F/Cross Mover F					
framehoogte	XS (48)	S (52)	M (56)	L (59)	XL (62)
zitbuislengte	A 480 mm	520 mm	560 mm	590 mm	620 mm
bovenbuislengte	B 545 mm	560 mm	575 mm	595 mm	610 mm
achterbruglengte	C 440 mm	440 mm	440 mm	440 mm	440 mm
trapasoffset	D 60 mm	60 mm	60 mm	60 mm	60 mm
talhoofdengte	E 125 mm	140 mm	150 mm	170 mm	200 mm
balhoofdhoek	α 70,5°	71,5°	72°	72,5°	72,5°
zitbuishoek	β 74,5°	74,5°	74°	73,5°	73,5°

Cross Flyer F					
framehoogte	XS (48)	S (52)	M (56)	L (59)	XL (62)
zitbuislengte	A 480 mm	520 mm	560 mm	590 mm	620 mm
bovenbuislengte	B 535 mm	550 mm	565 mm	585 mm	600 mm
achterbruglengte	C 445 mm	445 mm	445 mm	445 mm	445 mm
trapasoffset	D 60 mm	60 mm	60 mm	60 mm	60 mm
talhoofdengte	E 125 mm	140 mm	150 mm	170 mm	200 mm
balhoofdhoek	α 70,5°	71,5°	72°	72,5°	72,5°
zitbuishoek	β 74,5°	74,5°	74°	73,5°	73,5°

Info met betrekking tot de inhoud van deze catalogus:

Na redactiesluiting van deze uitgave kunnen producten aangepast zijn. Vraag daarom naar de meest actuele stand van zaken bij de BULLS-dealer in uw buurt. Alle producten in deze brochure zijn sportieve fietsen die niet uitgerust zijn voor de deelname in het verkeer. Vergissingen, drukfouten, uitleveringsmogelijkheden en technische wijzigingen voorbehouden. Kleurafwijkingen zijn druktechnisch niet te voorkomen.

Foto's: Armin Küstenbrück, Thomas Geisel