

GEOMETRIE CADRE

BLACK ADDER

	42 cm	47 cm	52 cm	57 cm
Hauteur cadre	420 mm	470 mm	520 mm	570 mm
Tube de selle A	420 mm	470 mm	520 mm	570 mm
Tube horizontal B	585 mm	600 mm	615 mm	630 mm
Long. des Bases C	425 mm	425 mm	430 mm	435 mm
Dif. a. b. /axe moyeu D	-25 mm	-25 mm	-25 mm	-25 mm
Tube de direction E	120 mm	130 mm	145 mm	175 mm
Angle de direction alpha	70°	70°	70°	70°
Angle Tube de selle beta	72°	72°	72°	72°

Tirone

	47 cm	52 cm	57 cm
A	470 mm	520 mm	570 mm
B	590 mm	605 mm	620 mm
C	425 mm	430 mm	430 mm
D	-25 mm	-25 mm	-20 mm
E	130 mm	145 mm	175 mm
alpha	70°	70°	70°
beta	73°	72,5°	72°

Bushmaster

	42 cm	47 cm	52 cm	57 cm
A	420 mm	470 mm	520 mm	570 mm
B	575 mm	590 mm	605 mm	620 mm
C	425 mm	425 mm	430 mm	435 mm
D	-30 mm	-25 mm	-25 mm	-25 mm
E	120 mm	130 mm	145 mm	175 mm
alpha	70°	70°	70°	70°
beta	73,5°	73°	72,5°	72°

Copperhead 3 Plus Carbon

	40 cm	44 cm	48 cm	52 cm
A	400 mm	440 mm	480 mm	520 mm
B	560 mm	580 mm	595 mm	605 mm
C	425 mm	425 mm	425 mm	425 mm
D	-38 mm	-38 mm	-38 mm	-38 mm
E	100 mm	115 mm	135 mm	155 mm
alpha	70°	70°	70°	70°
beta	73°	73°	73°	73°

Copperhead 3 Plus/3/2/1

	42 cm	47 cm	52 cm	57 cm
Hauteur cadre	420 mm	470 mm	520 mm	570 mm
Tube de selle A	420 mm	470 mm	520 mm	570 mm
Tube horizontal B	565 mm	580 mm	595 mm	610 mm
Long. des Bases C	425 mm	425 mm	430 mm	435 mm
Dif. a. b. /axe moyeu D	-35 mm	-30 mm	-30 mm	-30 mm
Tube de direction E	130 mm	140 mm	155 mm	185 mm
Angle de direction alpha	70°	70°	70°	70°
Angle Tube de selle beta	73°	73°	73°	73°

King Boa/King Boa Disc

	42 cm	47 cm	52 cm	57 cm
A	420 mm	470 mm	520 mm	570 mm
B	565 mm	580 mm	595 mm	610 mm
C	425 mm	425 mm	425 mm	425 mm
D	-35 mm	-30 mm	-30 mm	-30 mm
E	130 mm	140 mm	155 mm	185 mm
alpha	70°	70°	70°	70°
beta	73°	73°	73°	73°

Aminga

	38 cm	42 cm	47 cm	52 cm
A	380 mm	420 mm	470 mm	520 mm
B	545 mm	560 mm	565 mm	590 mm
C	425 mm	425 mm	425 mm	425 mm
D	-30 mm	-30 mm	-25 mm	-25 mm
E	120 mm	120 mm	130 mm	145 mm
alpha	70°	70°	70°	70°
beta	73,5°	73,5°	73°	72,5°

Jinga

	38 cm	42 cm	47 cm	52 cm
Hauteur cadre	380 mm	420 mm	470 mm	520 mm
Tube de selle A	380 mm	420 mm	470 mm	520 mm
Tube horizontal B	540 mm	550 mm	565 mm	580 mm
Long. des Bases C	425 mm	425 mm	425 mm	425 mm
Dif. a. b. /axe moyeu D	-35 mm	-35 mm	-30 mm	-30 mm
Tube de direction E	130 mm	130 mm	140 mm	155 mm
Angle de direction alpha	70°	70°	70°	70°
Angle Tube de selle beta	73°	73°	73°	73°

Sugar Max

	S	M	L	Mesures compl.:
A	525 mm	525 mm	560 mm	Axe pédalier/ milieu tube horizontal
B	575 mm	595 mm	615 mm	S = 415 mm
C	430 mm	430 mm	430 mm	M = 445 mm
D	-10 mm	-10 mm	-10 mm	L = 495 mm
E	125 mm	145 mm	180 mm	
alpha	70°	70°	70°	
beta	73°	73°	73°	

Copperhead 3 FS/Plus

	43 cm	48 cm	53 cm
A	430 mm	480 mm	530 mm
B	575 mm	595 mm	605 mm
C	430 mm	430 mm	430 mm
D	-10 mm	-10 mm	-10 mm
E	120 mm	130 mm	140 mm
alpha	70°	70°	70°
beta	72,5°	72,5°	72,5°

Wild Mojo/Wild Cup

	43 cm	48 cm	53 cm
Hauteur cadre	430 mm	480 mm	530 mm
Tube de selle A	430 mm	480 mm	530 mm
Tube horizontal B	575 mm	590 mm	605 mm
Long. des Bases C	440 mm	440 mm	440 mm
Dif. a. b. /axe moyeu D	0 mm	0 mm	0 mm
Tube de direction E	120 mm	130 mm	140 mm
Angle de direction alpha	69°	69°	69°
Angle Tube de selle beta	72,5°	72,5°	72,5°

Wild Card

	43 cm	48 cm	53 cm
A	430 mm	480 mm	530 mm
B	575 mm	590 mm	605 mm
C	445 mm	445 mm	445 mm
D	-15 mm	-15 mm	-15 mm
E	120 mm	130 mm	140 mm
alpha	69,5°	69,5°	69,5°
beta	72,5°	72,5°	72,5°

Devilzone 3

	38 cm	42 cm	47 cm	52 cm
A	380 mm	420 mm	470 mm	520 mm
B	545 mm	560 mm	575 mm	590 mm
C	430 mm	430 mm	430 mm	430 mm
D	-20 mm	-15 mm	-15 mm	-15 mm
E	130 mm	130 mm	140 mm	155 mm
alpha	69°	69°	69°	69°
beta	73°	73°	73°	73°

Aquarius

	245,5 mm
A	245,5 mm
B	520,5 mm
C	349 mm
D	34,9 mm
E	100 mm
alpha	74°
beta	70,5°

Pow

	241,7 mm
A	241,7 mm
B	507,5 mm
C	352 mm
D	37,9 mm
E	100 mm
alpha	74,5°
beta	71°

Instructions de ce catalogue:

Après la mise sous presse de ce catalogue, des modifications sur les produits sont possibles. Pour tous renseignements adressez-vous au revendeur BULLS le plus proche. Dans l'ensemble du catalogue, tous produits non homologués, ne sont pas autorisés à circuler sur route. Nous déclinons toutes responsabilités quant aux erreurs, erreurs typographiques, problèmes de livraison, et toutes autres modifications techniques. Réserves. Des différences de coloris peuvent être conditionnées par les techniques polygraphiques.

Photos: Armin Küstenbrück, Daniel Geiger, Simon Hausberger, Thomas Geisel, Michael Ricks



Tim Böhme
Vice-Champion d'Allemagne Marathon 2009

Stefan Sahn
Vice-Champion d'Allemagne Marathon 2008

Thomas Dietsch
Champion de France Marathon 2009

Karl Platt
Champion d'Allemagne Marathon 2008

Night Hawk

	50 cm	53 cm	56 cm	59 cm
Hauteur cadre	500 mm	530 mm	560 mm	590 mm
Tube de selle A	500 mm	530 mm	560 mm	590 mm
Tube horizontal B	550 mm	570 mm	590 mm	605 mm
Long. des Bases C	405 mm	410 mm	410 mm	410 mm
Dif. a. b./axe moyen D	-67 mm	-67 mm	-67 mm	-67 mm
Tube de direction E	150 mm	170 mm	190 mm	200 mm
Angle de direction α	72,5°	73°	73°	73,5°
Angle Tube de selle β	73,5°	73°	73°	73°

Desert Falcon

	50 cm	52 cm	54 cm	56 cm	58 cm	60 cm	62 cm	64 cm
Hauteur cadre	500 mm	520 mm	540 mm	560 mm	580 mm	600 mm	620 mm	640 mm
Tube de selle A	500 mm	520 mm	540 mm	560 mm	580 mm	600 mm	620 mm	640 mm
Tube horizontal B	530 mm	540 mm	550 mm	565 mm	575 mm	585 mm	595 mm	605 mm
Long. des Bases C	410 mm	410 mm	410 mm	410 mm	410 mm	410 mm	410 mm	410 mm
Dif. a. b./axe moyen D	-70 mm	-65 mm	-65 mm	-65 mm	-65 mm	-65 mm	-65 mm	-65 mm
Tube de direction E	120 mm	140 mm	150 mm	170 mm	190 mm	215 mm	225 mm	230 mm
Angle de direction α	72°	72,5°	72,5°	72,5°	72,5°	73°	73°	73°
Angle Tube de selle β	74,5°	74,5°	74°	73,5°	73,5°	73°	72,5°	72°

Ancura

	48 cm	50 cm	52 cm	54 cm
Hauteur cadre	480 mm	500 mm	520 mm	540 mm
Tube de selle A	480 mm	500 mm	520 mm	540 mm
Tube horizontal B	505 mm	515 mm	525 mm	535 mm
Long. des Bases C	410 mm	410 mm	410 mm	410 mm
Dif. a. b./axe moyen D	-70 mm	-70 mm	-65 mm	-65 mm
Tube de direction E	110 mm	120 mm	140 mm	150 mm
Angle de direction α	71°	72°	72,5°	72,5°
Angle Tube de selle β	74,5°	74,5°	74,5°	74°

Harrier

	50 cm	52 cm	54 cm	56 cm	58 cm	60 cm	62 cm	64 cm
Hauteur cadre	500 mm	520 mm	540 mm	560 mm	580 mm	600 mm	620 mm	640 mm
Tube de selle A	500 mm	520 mm	540 mm	560 mm	580 mm	600 mm	620 mm	640 mm
Tube horizontal B	525 mm	530 mm	540 mm	550 mm	565 mm	575 mm	585 mm	595 mm
Long. des Bases C	410 mm	410 mm	410 mm	410 mm	410 mm	410 mm	410 mm	410 mm
Dif. a. b./axe moyen D	-70 mm	-65 mm	-65 mm	-65 mm	-65 mm	-65 mm	-65 mm	-65 mm
Tube de direction E	120 mm	140 mm	150 mm	170 mm	190 mm	215 mm	225 mm	230 mm
Angle de direction α	72°	72,5°	72,5°	72,5°	72,5°	73°	73°	73°
Angle Tube de selle β	74,5°	74,5°	74°	73,5°	73,5°	73°	72,5°	72°

Street Mover

	44 cm	48 cm	54 cm	58 cm	61 cm
Hauteur cadre	440 mm	480 mm	540 mm	580 mm	610 mm
Tube de selle A	440 mm	480 mm	540 mm	580 mm	610 mm
Tube horizontal B	575 mm	590 mm	600 mm	610 mm	630 mm
Long. des Bases C	440 mm	440 mm	440 mm	440 mm	440 mm
Dif. a. b./axe moyen D	-60 mm	-55 mm	-55 mm	-55 mm	-55 mm
Tube de direction E	130 mm	130 mm	135 mm	150 mm	160 mm
Angle de direction α	71°	71°	71°	71°	71°
Angle Tube de selle β	74,5°	73,5°	73,5°	73°	72,5°

Cross RS

	44 cm	48 cm	54 cm	58 cm	61 cm
Hauteur cadre	440 mm	480 mm	540 mm	580 mm	610 mm
Tube de selle A	440 mm	480 mm	540 mm	580 mm	610 mm
Tube horizontal B	575 mm	590 mm	600 mm	610 mm	630 mm
Long. des Bases C	440 mm	440 mm	440 mm	440 mm	440 mm
Dif. a. b./axe moyen D	-55 mm	-45 mm	-45 mm	-45 mm	-45 mm
Tube de direction E	130 mm	130 mm	135 mm	150 mm	160 mm
Angle de direction α	71°	71°	71°	71°	71°
Angle Tube de selle β	74,5°	73,5°	73,5°	73°	72,5°

Cross Mover

	44 cm	48 cm	54 cm	58 cm	61 cm
Hauteur cadre	440 mm	480 mm	540 mm	580 mm	610 mm
Tube de selle A	440 mm	480 mm	540 mm	580 mm	610 mm
Tube horizontal B	575 mm	590 mm	600 mm	610 mm	630 mm
Long. des Bases C	440 mm	440 mm	440 mm	440 mm	440 mm
Dif. a. b./axe moyen D	-60 mm	-55 mm	-55 mm	-55 mm	-55 mm
Tube de direction E	130 mm	130 mm	135 mm	150 mm	160 mm
Angle de direction α	71°	71°	71°	71°	71°
Angle Tube de selle β	74,5°	73,5°	73,5°	73,5°	73,5°

Cross Flyer

	44 cm	48 cm	54 cm	58 cm	61 cm
Hauteur cadre	440 mm	480 mm	540 mm	580 mm	610 mm
Tube de selle A	440 mm	480 mm	540 mm	580 mm	610 mm
Tube horizontal B	565 mm	580 mm	590 mm	600 mm	610 mm
Long. des Bases C	440 mm	440 mm	440 mm	440 mm	440 mm
Dif. a. b./axe moyen D	-60 mm	-55 mm	-55 mm	-55 mm	-55 mm
Tube de direction E	130 mm	130 mm	135 mm	150 mm	160 mm
Angle de direction α	71°	71°	71°	71°	71°
Angle Tube de selle β	74,5°	73,5°	73,5°	73,5°	73,5°

Cross Flyer 8 vit.

	44 cm	48 cm	54 cm	58 cm	61 cm
Hauteur cadre	440 mm	480 mm	540 mm	580 mm	610 mm
Tube de selle A	440 mm	480 mm	540 mm	580 mm	610 mm
Tube horizontal B	565 mm	580 mm	590 mm	600 mm	610 mm
Long. des Bases C	445 mm	445 mm	445 mm	445 mm	445 mm
Dif. a. b./axe moyen D	-60 mm	-55 mm	-55 mm	-55 mm	-55 mm
Tube de direction E	130 mm	130 mm	135 mm	150 mm	160 mm
Angle de direction α	71°	71°	71°	71°	71°
Angle Tube de selle β	74,5°	73,5°	73,5°	73,5°	73,5°

Cross Flyer F 8 vit.

	44 cm	48 cm	54 cm	58 cm	61 cm
Hauteur cadre	440 mm	480 mm	540 mm	580 mm	610 mm
Tube de selle A	440 mm	480 mm	540 mm	580 mm	610 mm
Tube horizontal B	565 mm	580 mm	590 mm	600 mm	610 mm
Long. des Bases C	445 mm	445 mm	445 mm	445 mm	445 mm
Dif. a. b./axe moyen D	-60 mm	-55 mm	-55 mm	-55 mm	-55 mm
Tube de direction E	130 mm	130 mm	135 mm	160 mm	180 mm
Angle de direction α	71°	71°	71°	71°	71°
Angle Tube de selle β	74,5°	73,5°	73,5°	73,5°	73,5°

Cross Racer

	44 cm	48 cm	54 cm	58 cm	61 cm
Hauteur cadre	440 mm	480 mm	540 mm	580 mm	610 mm
Tube de selle A	440 mm	480 mm	540 mm	580 mm	610 mm
Tube horizontal B	565 mm	580 mm	590 mm	600 mm	610 mm
Long. des Bases C	440 mm	440 mm	440 mm	440 mm	440 mm
Dif. a. b./axe moyen D	-60 mm	-55 mm	-55 mm	-55 mm	-55 mm
Tube de direction E	130 mm	130 mm	135 mm	160 mm	180 mm
Angle de direction α	71°	71°	71°	71°	71°
Angle Tube de selle β	74,5°	73,5°	73,5°	73,5°	73,5°

plus d'informations
sur les géométries
www.bulls.de

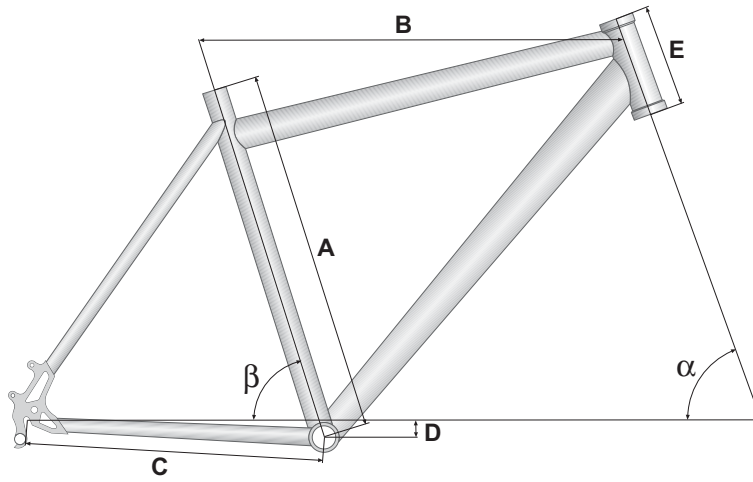

GEOMETRIE CADRE

King Cobra/King Cobra Disc

	38 cm	42 cm	47 cm	52 cm	57 cm
Hauteur cadre					
Tube de selle A	380 mm	420 mm	470 mm	520 mm	570 mm
Tube horizontal B	545 mm	560 mm	575 mm	590 mm	605 mm
Long. des Bases C	430 mm	430 mm	430 mm	430 mm	430 mm
Dif. a. b./axe moyeu D	-40 mm	-40 mm	-35 mm	-35 mm	-35 mm
Tube de direction E	130 mm	130 mm	140 mm	155 mm	185 mm
Angle de direction α	70°	70°	70°	70°	70°
Angle Tube de selle β	73°	73°	73°	73°	73°

Bushtail

	38 cm	42 cm	47 cm	52 cm	57 cm
A	380 mm	420 mm	470 mm	520 mm	570 mm
B	545 mm	560 mm	575 mm	590 mm	605 mm
C	430 mm	430 mm	430 mm	430 mm	430 mm
D	-40 mm	-40 mm	-35 mm	-35 mm	-35 mm
E	130 mm	130 mm	140 mm	155 mm	185 mm
α	70°	70°	70°	70°	70°
β	73°	73°	73°	73°	73°

Sharptail 2/Sharptail 1

	38 cm	42 cm	47 cm	52 cm	57 cm
A	380 mm	420 mm	470 mm	520 mm	570 mm
B	545 mm	560 mm	575 mm	590 mm	605 mm
C	430 mm	430 mm	430 mm	430 mm	430 mm
D	-40 mm	-40 mm	-35 mm	-35 mm	-35 mm
E	130 mm	130 mm	140 mm	155 mm	185 mm
α	70°	70°	70°	70°	70°
β	73°	73°	73°	73°	73°

Black Street

	38 cm	42 cm	47 cm	52 cm	57 cm
A	380 mm	420 mm	470 mm	520 mm	570 mm
B	545 mm	560 mm	575 mm	590 mm	605 mm
C	430 mm	430 mm	430 mm	430 mm	430 mm
D	-40 mm	-40 mm	-35 mm	-35 mm	-35 mm
E	130 mm	130 mm	140 mm	155 mm	185 mm
α	70°	70°	70°	70°	70°
β	73°	73°	73°	73°	73°

Sharptail Street

♂	38 cm	42 cm	47 cm	52 cm	57 cm	♀	41 cm	46 cm	52 cm
A	380 mm	420 mm	470 mm	520 mm	570 mm	A	410 mm	460 mm	520 mm
B	545 mm	560 mm	575 mm	590 mm	605 mm	B	560 mm	575 mm	590 mm
C	430 mm	430 mm	430 mm	430 mm	430 mm	C	430 mm	430 mm	430 mm
D	-40 mm	-40 mm	-35 mm	-35 mm	-35 mm	D	-40 mm	-35 mm	-35 mm
E	130 mm	130 mm	140 mm	155 mm	185 mm	E	130 mm	140 mm	155 mm
α	70°	70°	70°	70°	70°	α	70°	70°	70°
β	73°	73°	73°	73°	73°	β	73°	73°	73°

Vanida

	38 cm	42 cm	47 cm	52 cm
A	380 mm	420 mm	470 mm	520 mm
B	535 mm	545 mm	560 mm	575 mm
C	425 mm	425 mm	425 mm	425 mm
D	-35 mm	-35 mm	-30 mm	-30 mm
E	130 mm	130 mm	140 mm	155 mm
α	70°	70°	70°	70°
β	73°	73°	73°	73°

Zarena

	38 cm	42 cm	47 cm	52 cm
A	380 mm	420 mm	470 mm	520 mm
B	535 mm	545 mm	560 mm	575 mm
C	425 mm	425 mm	425 mm	425 mm
D	-35 mm	-35 mm	-30 mm	-30 mm
E	130 mm	130 mm	140 mm	155 mm
α	70°	70°	70°	70°
β	73°	73°	73°	73°

Wild Beast

	43 cm	48 cm	53 cm
A	435 mm	485 mm	533 mm
B	560 mm	575 mm	590 mm
C	435 mm	435 mm	435 mm
D	-15 mm	-15 mm	-15 mm
E	130 mm	130 mm	140 mm
α	71°	71°	71°
β	73°	71°	71°

Wild One

	43 cm	48 cm	53 cm
A	435 mm	485 mm	533 mm
B	560 mm	575 mm	590 mm
C	435 mm	435 mm	435 mm
D	-15 mm	-15 mm	-15 mm
E	130 mm	130 mm	140 mm
α	71°	71°	71°
β	69°	69°	69°

Devilzone 2/Devilzone 1

	38 cm	42 cm	47 cm	52 cm	57 cm
A	380 mm	420 mm	470 mm	520 mm	570 mm
B	545 mm	560 mm	575 mm	590 mm	605 mm
C	420 mm	420 mm	420 mm	420 mm	420 mm
D	-20 mm	-15 mm	-15 mm	-15 mm	-15 mm
E	130 mm	130 mm	140 mm	155 mm	155 mm
α	69°	69°	69°	69°	69°
β	73°	73°	73°	73°	73°

Stone Cold

	38 cm	42 cm	47 cm	52 cm	57 cm
A	380 mm	420 mm	470 mm	520 mm	570 mm
B	545 mm	560 mm	575 mm	590 mm	605 mm
C	420 mm	420 mm	420 mm	420 mm	420 mm
D	-20 mm	-15 mm	-15 mm	-15 mm	-15 mm
E	130 mm	130 mm	140 mm	155 mm	155 mm
α	69°	69°	69°	69°	69°
β	73°	73°	73°	73°	73°

Novel/Novice 20

	241,7 mm
A	241,7mm
B	469 mm
C	349 mm
D	37,9mm
E	100 mm
α	74,5°
β	71°

Novice Free/Novice Dirt

	241,7 mm
A	241,7 mm
B	469 mm
C	365 mm
D	37,9 mm
E	100 mm
α	74,5°
β	71°

Vulture 2/Vulture 1

	47 cm	50 cm	53 cm	56 cm	59 cm
A	470 mm	500 mm	530 mm	560 mm	590 mm
B	520 mm	530 mm	550 mm	565 mm	585 mm
C	410 mm	410 mm	410 mm	410 mm	410 mm
D	-70 mm	-70 mm	-65 mm	-65 mm	-65 mm
E	120 mm	120 mm	150 mm	170 mm	215 mm
α	72°	72°	72,5°	72,5°	73°
β	74,5°	74,5°	74°	73,5°	73°

Cross Mover F

♂	44 cm	48 cm	54 cm	58 cm	61 cm	♀
A	440 mm	480 mm	540 mm	580 mm	610 mm	A
B	575 mm	590 mm	600 mm	610 mm	630 mm	B
C	440 mm	440 mm	440 mm	440 mm	440 mm	C
D	-60 mm	-55 mm	-55 mm	-55 mm	-55 mm	D
E	130 mm	130 mm	135 mm	160 mm	180 mm	E
α	71°	71°	71°	71°	71°	α
β	74,5°	73,5°	73,5°	73,5°	73,5°	β

Sturmvogel

♂	42 cm	47 cm	52 cm	♀
A	420 mm	470 mm	520 mm	A
B	570 mm	585 mm	600 mm	B
C	430 mm	430 mm	430 mm	C
D	-43 mm	-43 mm	-43 mm	D
E	130 mm	140 mm	160 mm	E
α	70,5°	71°	71°	α
β	74°	73°	73°	β

Cross Swing/Cross Tail/Cross Bike F/2/1

	44 cm	48 cm	54 cm	58 cm	61 cm		44 cm	48 cm	54 cm
A	440 mm	480 mm	540 mm	580 mm	610 mm	A	440 mm	480 mm	540 mm
B	565 mm	580 mm	590 mm	600 mm	620 mm	B	555 mm	570 mm	580 mm
C	440 mm	440 mm	440 mm	440 mm	440 mm	C	440 mm	440 mm	440 mm
D	-60 mm	-55 mm	-55 mm	-55 mm	-55 mm	D	-60 mm	-55 mm	-55 mm
E	130 mm	130 mm	135 mm	150 mm	160 mm	E	130 mm	130 mm	135 mm
α	71°	71°	71°	71°	71°	α	71°	71°	71°
β	74,5°	73,5°	73,5°	73,5°	73,5°	β	74,5°	73,5°	73,5°

Street Flyer

♂	44 cm	48 cm	54 cm	58 cm	61 cm	♀	44 cm	48 cm	54 cm
A	440 mm	480 mm	540 mm	580 mm	610 mm	A	440 mm	480 mm	540 mm
B	565 mm	580 mm	590 mm	600 mm	620 mm	B	555 mm	570 mm	580 mm
C	440 mm	440 mm	440 mm	440 mm	440 mm	C	440 mm	440 mm	440 mm
D	-60 mm	-55 mm	-55 mm	-55 mm	-55 mm	D	-60 mm	-55 mm	-55 mm
E	130 mm	130 mm	135 mm	150 mm	160 mm	E	130 mm	130 mm	135 mm
α	71°	71°	71°	71°	71°	α	71°	71°	71°
β	74,5°	73,5°	73,5°	73,5°	73,5°	β	74,5°	73,5°	73,5°